

# NIMBUS

## PARTITIONING SYSTEM INSTALLATION GUIDE



**HALE MANUFACTURING LTD**  
PARTITION AND WASHROOM SYSTEMS

## STEP 1

1. Firstly, establish the level of the floor, taking into account that the legs are 150mm high.

As an aid for installers, we have included leveling blocks.

Place these on the floor at the position of the divisional panel and pack to level off the highest point on the floor. This will determine the height of the rear channel.

2. Screw the 1672mm wall channel (and 1780mm wall channel in using an end panel) to the rear wall with 40mm screws. Use 6mm masonry bit.

Use masonry anchors (rawl plugs) to brick or concrete.

Ensure that the bottom of the channels are level across the back wall. Silicone to be placed behind wall channels.

3. Fit 1780mm side wall channels to the side wall.

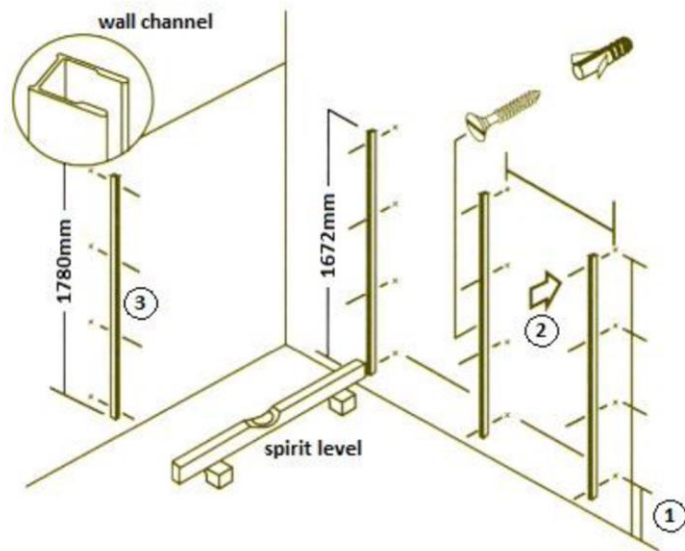

## STEP 2

1. Place the partition (standard 1700mm high) panels into the rear wall channels.
2. If you are installing more than 2 cubicles, it is advisable not to screw the division panel at this stage as you may need to adjust the panels forward to line up the doors and front panels.
3. Fit the nib (standard 1800mm high) into the side wall channel. Plumb and fix.

**Note:** With the Hale Nimbus Compact Partitioning Systems, a headrail will be supplied with divisional panels over 1500mm deep.

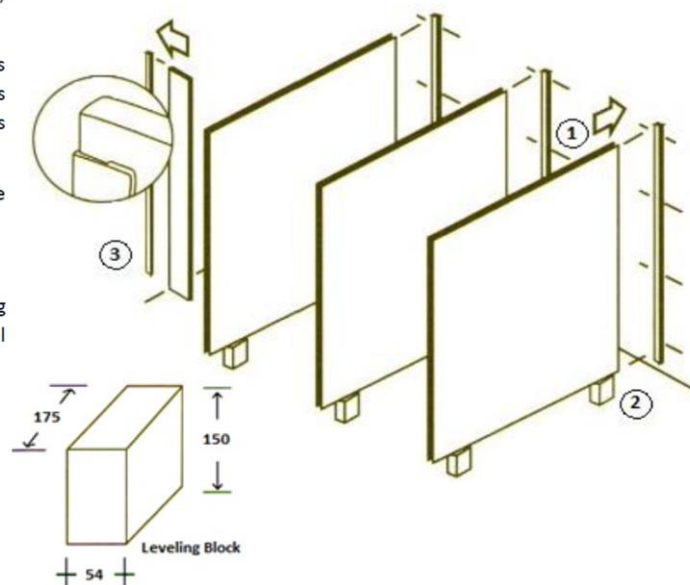

**HALE MANUFACTURING LTD**  
PARTITION AND WASHROOM SYSTEMS

## STEP 3

1. Fit wall channel to frontal as per plan.
2. Fit frontal nib to the divisional partitions and screw fix.
3. Cut head rail to desired length and place in position over the nib and frontals.  
Screw head rail to nib only at this stage.
4. Place the 605mm x 18mm (13mm for Multipurpose & Innovations Compact Laminate) Infill Cap between the nib and first frontal.
5. Push frontal hard up against insert and secure headrail to frontal. Allow 2 screws per frontal and repeat for remainder of the cubicles.

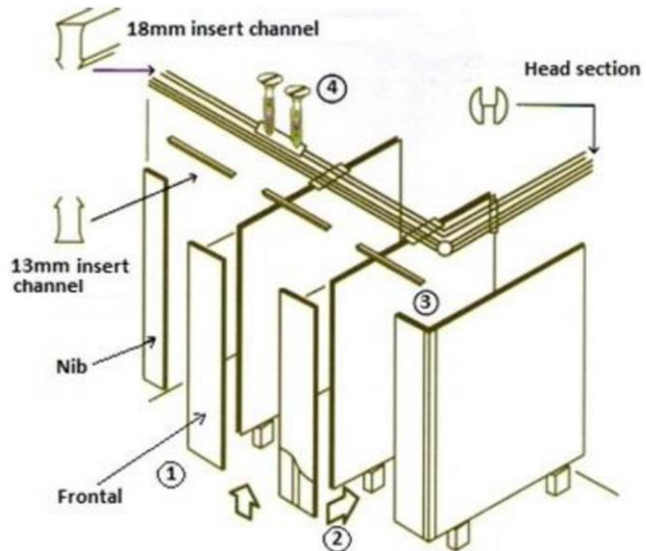

## STEP 4

1. Hang doors by fixing the hinges. When operating properly, secure all divisional panels to the rear channel with 3 screws. Note 3 hinges must be used.
2. Fix the indicator locks. Drill and fix keepers. Be careful not to drill through panels. USE DRILL STOP.
3. When fixing hardware to shower partitioning systems, it is advisable to place a small amount of clear silicone in the screw holes prior to fixing.
4. Locate leg position on floor and fix plate to floor.
5. Fix leg to front panel.

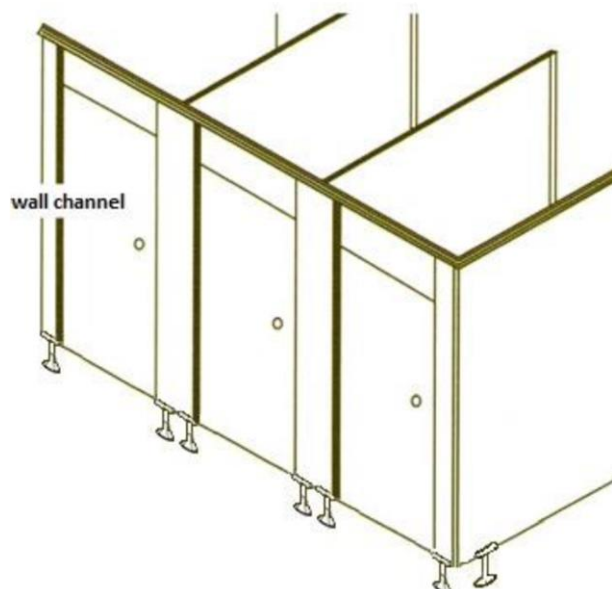

**HALE MANUFACTURING LTD**  
PARTITION AND WASHROOM SYSTEMS