

CONTEMPORARY

PARTITIONING SYSTEM INSTALLATION GUIDE



HALE MANUFACTURING LTD
PARTITION AND WASHROOM SYSTEMS

STEP 1

1. Firstly, establish the level of the floor, taking into account that the legs have an adjustable range of between 170-190mm.

As an aid for installers, we have included levelling blocks.

Place these on the floor at the position of the divisional panel and back to level off the highest point on the floor. This will determine the height of the rear channel.
2. Screw the 1700mm wall channel (and 1777mm wall channel in using an end panel) to the rear wall with 40mm screws. Use 6mm masonry bit. Use masonry anchors (raw plugs) to brick or concrete.

Ensure that the bottom of the channels to be placed behind wall channels.
3. Fit 1777mm side wall channels to the side wall.

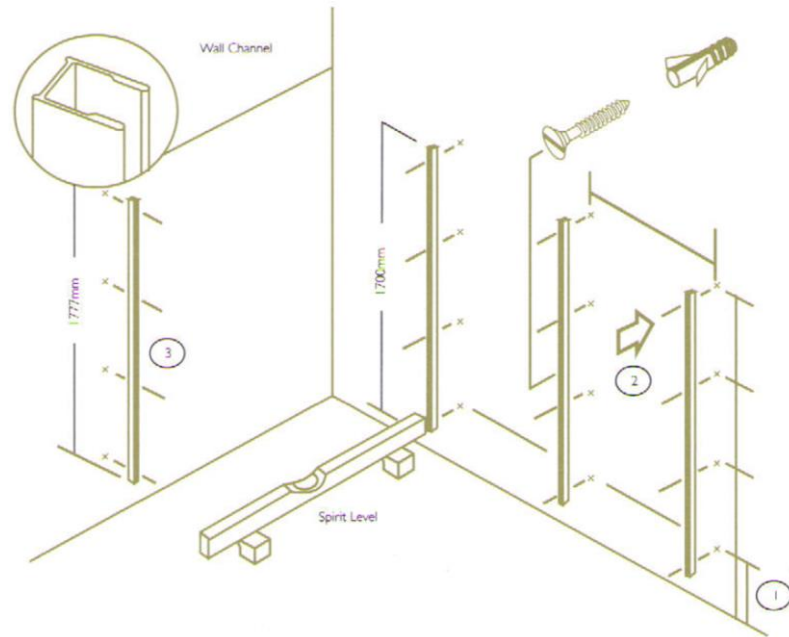

STEP 2

1. Place the partition (standard 1700mm high) panels into rear wall channels
2. If you are installing more than 2 cubicles, it is advisable not to screw the division panel at this stage as you may need to adjust the panels forward to line up the doors and front panels.
3. Fit the nib (standard 1800mm high) into the side wall channel. Plumb and fix.

Note: With the Laminex Multipurpose system, a headrail will be supplied with divisional panels over 1500mm deep.

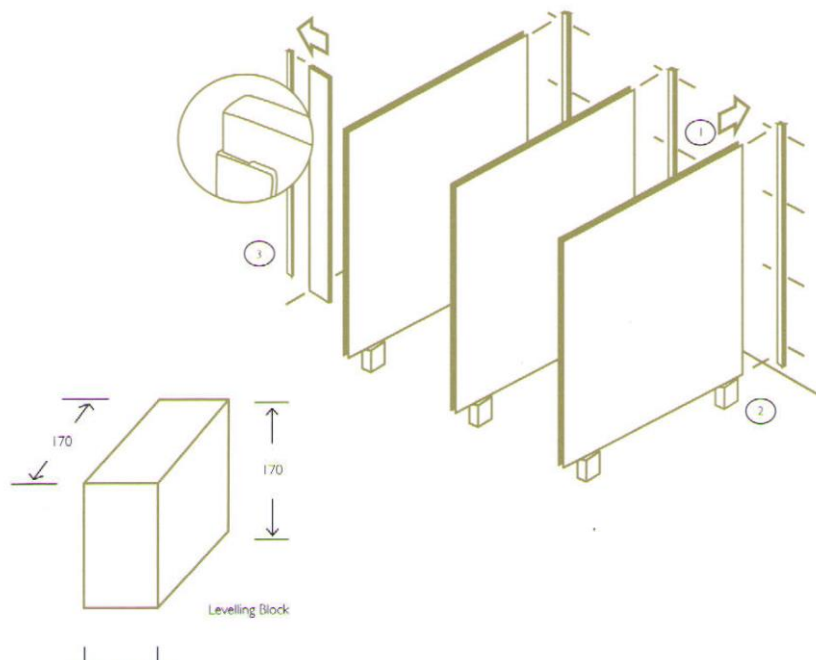

STEP 3

1. Fit wall channel to frontal as per plan.
2. Fit frontal nib to the divisional partitions and screw fix.
3. Cut head rail to desired length and place in position over the nib and frontals.
Screw head rail to nib only at this stage.
4. Place the 605mm 18mm infill cap between the nib and first frontal.
5. Push frontal hard up against insert and secure headrail to frontal. Allow 2 screws per frontal and repeat for the remainder of the cubicles.

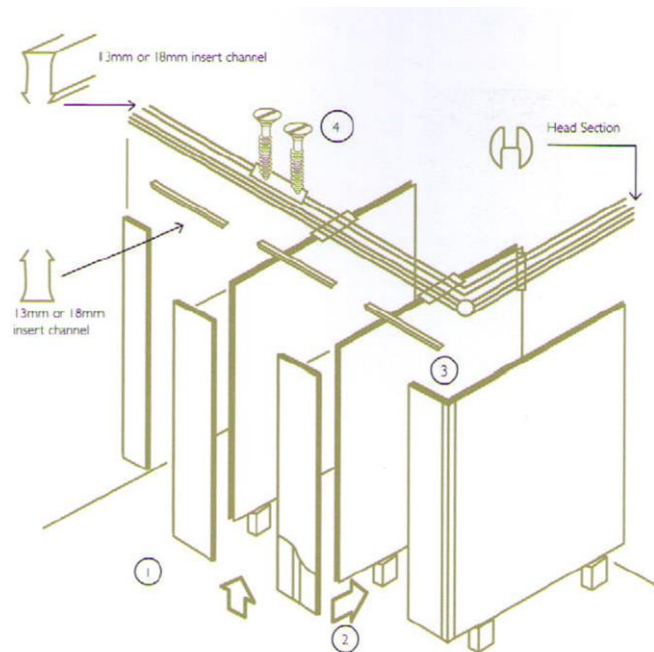

STEP 4

1. Hang doors by fixing the hinges 100mm up from bottom, 100mm from the top and in the centre.
When operating properly, secure all divisional panels to the rear channel with 3 screws. Note: 3 hinges must be used.
2. Fix the indicator locks.
3. When fixing hardware to shower partitioning systems, it is advisable to place a small amount of clear silicone in the screw holes prior to fixing.
4. Locate leg position on floor and fix plate to floor (remove leg via grub screw on side of base).
5. Refit leg to base and fix to panel.
6. Note for concealed foot assemblies, affix cover plate to back of foot to conceal fixing screws.

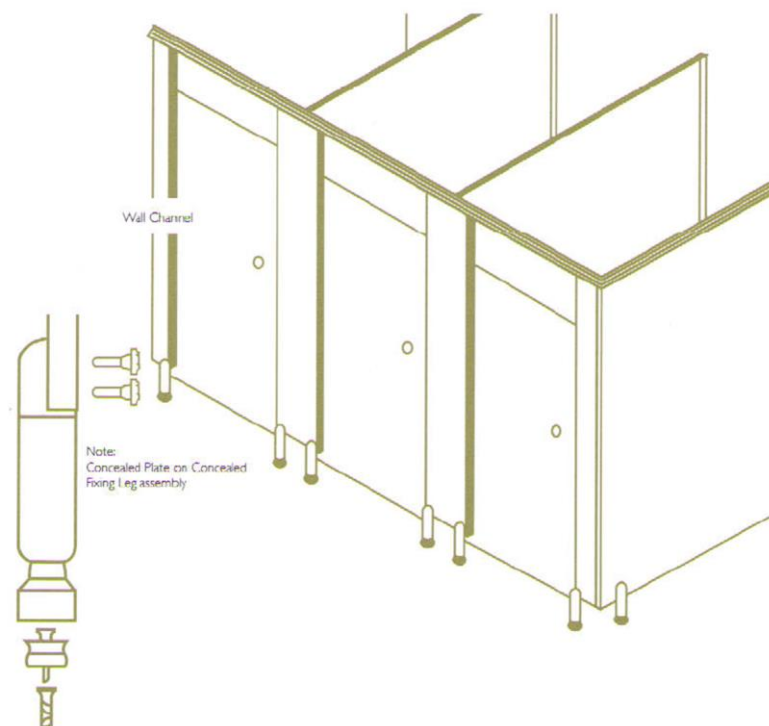

HALE MANUFACTURING LTD
PARTITION AND WASHROOM SYSTEMS

TYPICAL DETAIL

